

**SUNY**

# Upstate Cancer Center

Syracuse, New York



**Thesis Proposal**

Michael Kostick | Structural Option

Faculty Advisor: Dr. Richard Behr

December 9, 2011

## Table of Contents

Executive Summary.....	2
Introduction .....	3
Structural Systems .....	4
Building Key.....	4
Foundation.....	6
Framing System.....	7
Floor System.....	8
Roof System .....	8
Lateral System.....	9
Design Codes and Standards.....	11
Materials .....	12
Problem Statement.....	13
Proposed Solution.....	13
Breadth Topics .....	14
Breadth Topic 1 – Cost and Schedule Analysis .....	14
Breadth Topic 2 – Building Envelope and Façade Study.....	14
MAE Requirements .....	14
Tasks and Tools .....	15
Timeline (Spring Semester).....	17
Conclusion.....	18

## Executive Summary

The SUNY Upstate Cancer Center is a new, 90,000 square foot, five story healthcare facility on the Upstate Medical University campus in Syracuse, New York. Its current gravity system consists of composite steel metal deck on composite steel wide flange beams and girders. Lateral loads are resisted by a series of steel braced frames and/or steel moment frames. Presented in this document is a proposed subject of study within the field of structural engineering, regarding the Upstate Cancer Center that is to be conducted throughout the spring semester of 2012. Along with this, two architectural engineering breadth studies are also proposed for the spring semester.

As previously mentioned, the Upstate Cancer Center is currently composed of a steel superstructure. The proposed thesis will investigate substituting reinforced concrete for steel as the primary construction material. Three alternative flooring systems were studied in Technical Report 2, revealing that a two-way flat slab with drop panels was the most feasible substitute to the current steel system. After the appropriate floor system is selected, the gravity and lateral load resisting systems of the building will be redesigned. The existing foundation, consisting of cast-in-place grade beams resting on drilled caissons, will be evaluated and redesigned if necessary, to compensate for the changes to the superstructure.

The primary focus of this thesis is to learn the concepts of progressive collapse design. Once the preliminary redesign of the Upstate Cancer Center is completed, the system will be further altered to meet progressive collapse requirements established by the Unified Facilities Criteria and the General Services Administration. An ETABS computer model will be created to supplement the design process, and be used to determine design forces in members.

Two breadth studies will also be performed related to a discipline other than structural engineering. Because altering the primary structure of the Upstate Cancer Center from steel to concrete will most likely bring change to the cost and schedule of the building, a new schedule and cost analysis will be performed considering the reinforced concrete system. The new building cost and construction schedule will be compared to the existing one to evaluate the effectiveness of changing the structural system.

Finally, the second breadth study will investigate the energy efficiency of the current glass facade curtain wall through means of a heat transfer analysis. An alternative facade design will be produced with the intention of creating a more sustainable and efficient system. A comparison will be made between the new and existing wall systems.

## Introduction

The State University of New York's Upstate Medical University, located in Syracuse, New York will serve as the home to the new Upstate Cancer Center. Taking the place of an existing parking lot to the northwest of the Upstate Medical University Hospital, the new center will not only serve as the region's premiere outpatient adult and pediatric cancer center, but also link the university's Regional Oncology Center (ROC), Gamma Knife Center, and the Upstate Medical University Hospital. (See Figure 1)

Upon its completion, the five-story building will rise 72 feet to the roof level, 90 feet to the top of the rooftop parapets, and encompass 90,000 square feet. Floor one will house administration services, the radiology department, as well as intra operative suites. The second floor will be reserved for medical oncology while the third floor will be devoted entirely for pediatric oncology. Floors four and five will consist of shell space intended for future outfit and expansion. A two-story central plant containing electrical transformers and a full mechanical space serves as linkage between the cancer center and the existing ROC. (See Figure 1 – highlighted green)

The building is primarily clad in a soothing white insulated metal paneling with cold formed metal stud back up. This metal paneling is rather haphazardly disrupted by varying widths and heights of vertical bands of glazing. These bands consist of both vision and spandrel glazing, which is used to transition floor levels, hiding mechanical space and the structural floor. The exterior façade culminates at the three-story, northeast facing entrance atrium. Featuring a custom frit pattern, the northeast facing façade is enclosed by a full height, glazed curtain wall which provides solar shading as well as an aesthetically pleasing view. (See Figure 2)



**Figure 2** Exterior rendering of northeast entry façade. (Courtesy of EwingCole)



**Figure 1** Aerial map locating the building site. (Courtesy of Google Maps)

Upstate is committed to providing a comforting environment for its patients, providing amenities such as a meditation room, a boutique for gifts and apparel, and a four-season roof top healing garden. These gardens not only serve as a refreshing oasis, but also help to reduce the cooling costs for the Upstate Cancer Center, adding to Upstate's goal of achieving USGBC LEED Silver certification. Preliminary Construction on the 74 million dollar center began in March of 2011 and is expected to be completed by September of 2013.

## Structural Systems

### Building Key

In an attempt to better represent the building geometries, a three-dimensional Google SketchUp model (Figure 3) and a two-dimensional building plan (Figure 4) have been created. Main divisions of the building were divided and designated based on the location of expansion joints specified on Sheet A.3.7.4. (See Appendix A) The three-dimensional model below shows the entire SUNY Upstate Cancer Center in red. Directly beneath this is a similar model displaying the three major sections of the building: the Central Tower, the Central Plant, and the Imaging Building.

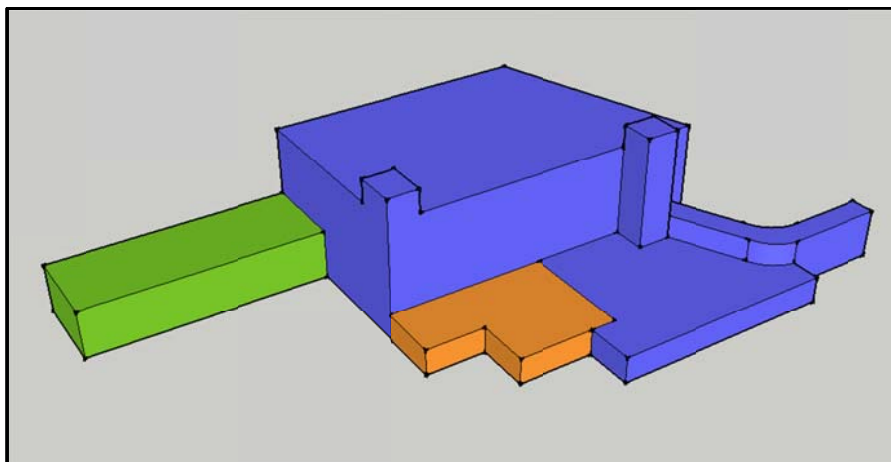
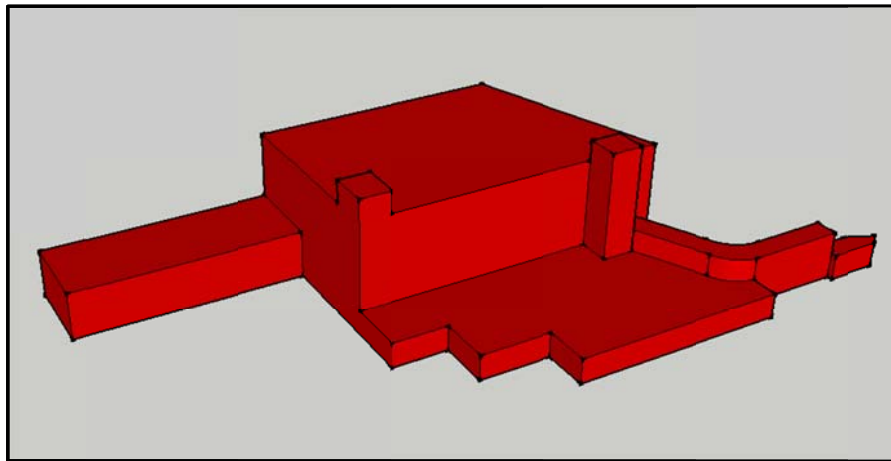

elow is a two dimensional representation of the building key. Color coding has been used to distinguish between different portions of the building as well as differing roof elevations. In addition, relevant building data such as story counts and basic dimensions have also been included. Building names assigned in this section will apply to data, calculations, and descriptions later in this report.

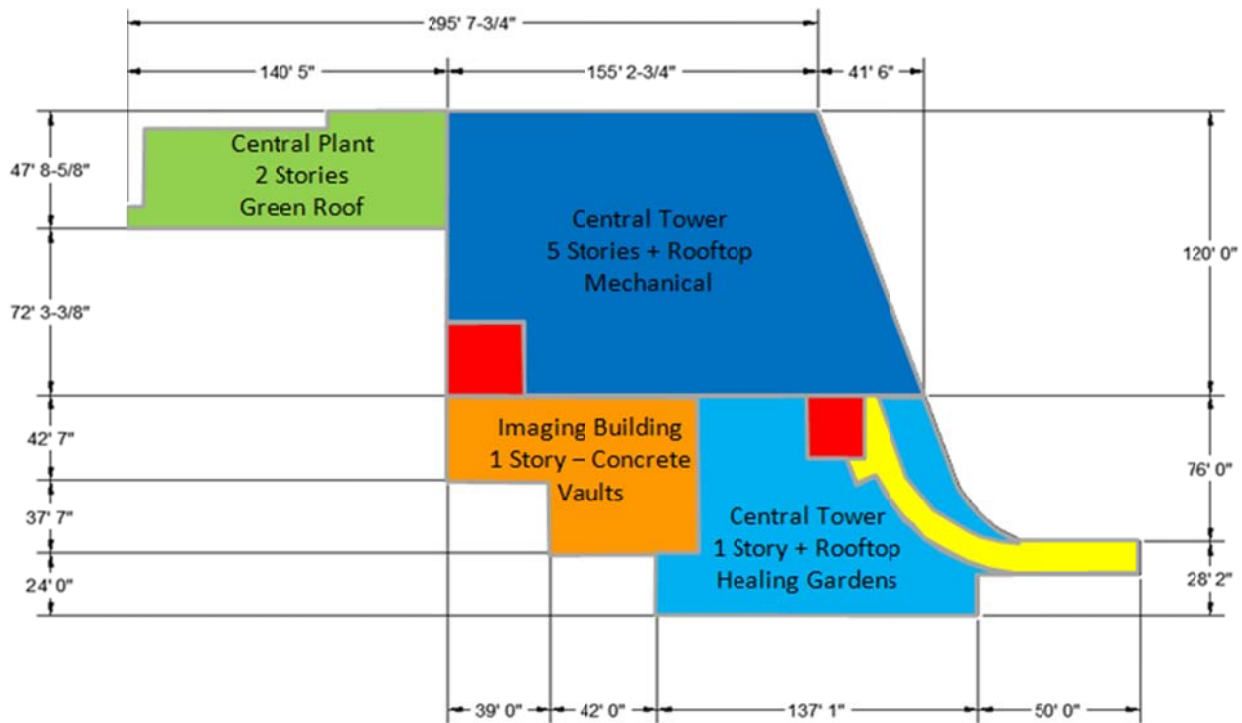

**Figure 4** Two-dimensional building key plan showing main building divisions, dimensions, and description. Diagram key given below.



Diagram Key / Roof Elevations	
<span style="color: blue;">■</span>	Central Tower – 72'-0"
<span style="color: green;">■</span>	Central Plant – 30'-0"
<span style="color: yellow;">■</span>	Public Access Corridor – 30'-0"
<span style="color: cyan;">■</span>	Central Tower – 16'-0"
<span style="color: orange;">■</span>	Imaging Building – 16'-0"
<span style="color: red;">■</span>	Elevator Core Shafts – 86' 6"

## Foundation

Atlantic Testing Laboratories (ATL), at the request of Upstate Medical University, conducted a subsurface and geotechnical evaluation of the project site. Testing purposes were to determine the subsurface soil and ground water conditions at the site, and assess their engineering significance. Several boring tests, locations specified by architect/engineer EwingCole, were performed by ATL, to a minimum depth of 12 feet throughout the site. Subsurface soil composition beneath the initial layers of top soil and asphalt, mainly consisted of silty, gravelly, sand; silty clay and clayey silt, organic silt; debris (brick and ash); and weathered gypsum. Weathered bedrock was discovered at depths ranging from 12 to 28 feet at different boring locations. Beneath the weathered rock, lies bedrock that consists of shale, gypsum, and dolostone deposits.

ATL's discoveries resulted in their recommendation of using a structural slab supported by a deep foundation system consisting of drilled piers (caissons) bearing on dolostone bedrock. The allowable rock bearing capacity of the specified bedrock was assessed at 40 kips per square foot (40 ksf). ATL recommends a minimum pier diameter of 30 inches drilled a minimum of 24 inches into the bedrock.

Following these recommendations, EwingCole designed a foundation consisting of cast-in-place grade beams (4000 psi minimum compressive strength) resting on drilled caissons (5000 psi minimum compressive strength) with a poured slab on grade (4000 psi minimum compressive strength). All reinforcing was specified as ASTM A615 Grade 60. Grade beams range in depth from 16 to 66 inches and in width from 18 to 116 inches. Typical longitudinal bars are number eights to number tens with use of number three or number four stirrups. The slab on grade is most commonly a depth of six inches with some areas up to twelve inches thick, reinforced with number four to number six longitudinal bars. A typical grade beam section is shown below. (Figure 5)

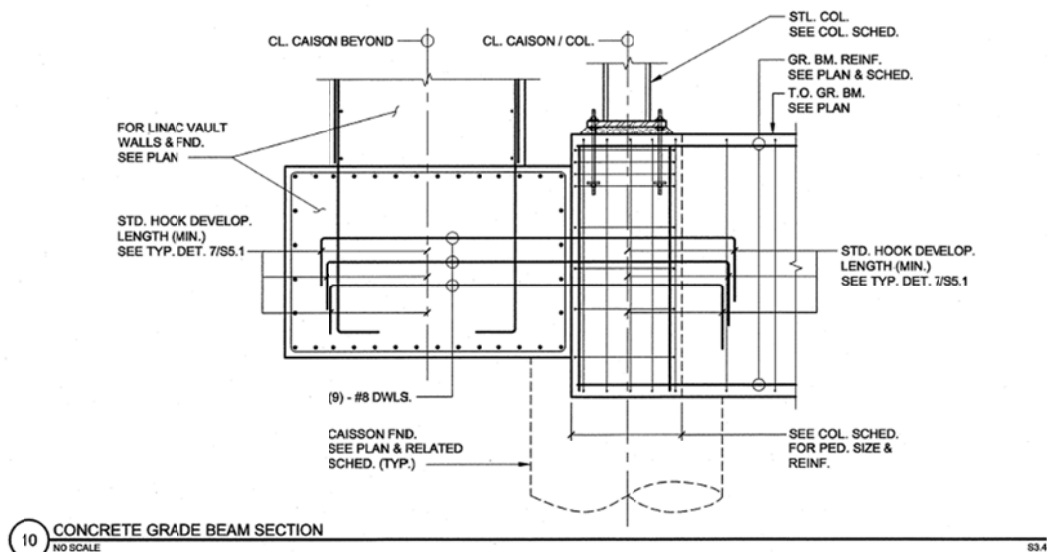

Figure 5 Typical grade beam section from sheet S3. 4  
(Courtesy of EwingCole)



## Framing System

The superstructure of the Upstate Cancer Center is composed of structural ASTM A992 GR 50 wide flange steel shapes. Columns are almost exclusively sized as W12's with a few exceptions, W14's, and spliced at a height of 36 feet, mid-way through floor three. This provides a typical floor to floor height of 14 feet with a ground floor height of 16 feet. Column weights vary from 24 lb/ft to 210 lb/ft.

A typical bay size throughout the building measures 30 feet by 30 feet with infill beams spaced evenly at a distance of ten feet on center, spanning 30 feet from girder to girder. Beams and Girders were designed compositely with the floor system through use of  $\frac{3}{4}$  inch by 5 inch long shear studs welded on the center line of the members. In addition to this, infill beams were generally designed with a  $\frac{3}{4}$  inch camber to compensate for excessive deflection. On a typical floor, beams range in size from W12x14's to W16x31's with the most common size being a W16x26. Girders range in size from W18x35's to W30x90's with the most common size being a W24x68 on a typical floor. Figure 6 shows a typical floor framing plan for floors two through four in the Central Tower.

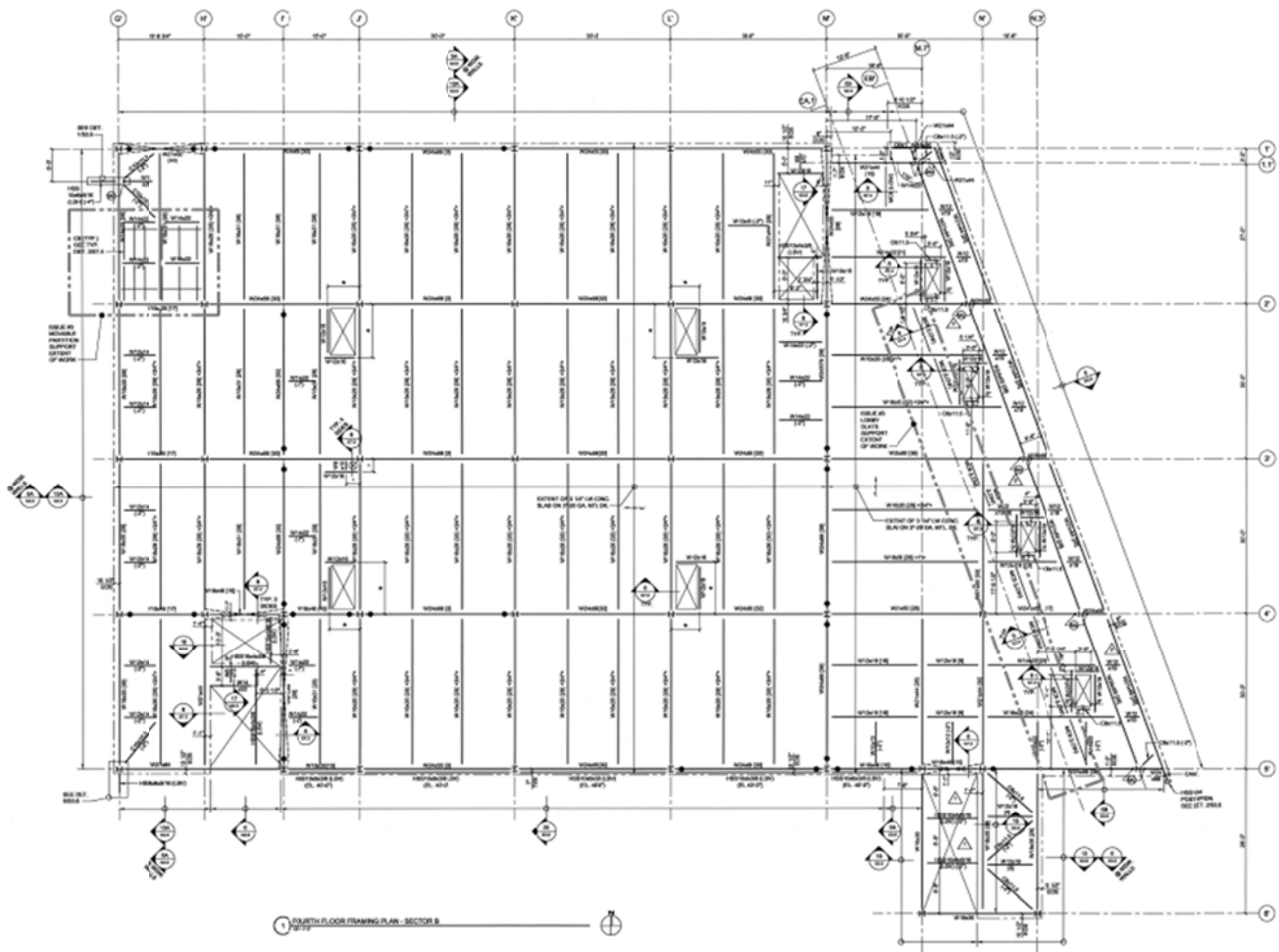

Figure 6 Typical framing layout (Central Tower) Floors two – four (Courtesy of EwingCole)



## Floor System

All elevated floors of the cancer center utilize a composite flooring system working integrally with the structural framing members discussed in the previous section. A typical floor assembly is comprised of 3 inch 20 gage galvanized steel deck with 3 ¼ inch lightweight concrete topping (110 pcf, 3000 psi minimum compressive strength), a total thickness of 6 ¼ inches. The deck is reinforced with ASTM A185 6x6 welded wire fabric (WWF). On the fifth floor, a 60 foot by 30 foot, two bay, section of floor reserved for a future MRI or PET-CV unit, uses a larger topping thickness of 5 ¼ inches. The floor assembly for this particular area results as 3 inch 20 gage galvanized steel deck with 5 ¼ inch lightweight concrete topping, a total thickness of 8 ¼ inches, and ASTM A185 6x6 welded wire fabric.

All decking is specified as a minimum of two span continuous. The typical span length is approximately 10 feet spanning perpendicular to the infill beams, typically W16x26's. In the two story central plant, housing the center's mechanical equipment, typical deck spans decrease to approximately six to seven feet. The decrease of span length allows the floor system to support a larger superimposed load, i.e., mechanical and electrical equipment.

## Roof System

The Upstate Cancer Center uses three separate roofing assemblies: metal roof deck; concrete roof deck; and a green roof. The metal roof deck is the most commonly used assembly of the three and consists of a 60 mil EPDM membrane, 5/8 inch cover board, 4 inch minimum rigid insulation, and a gypsum thermal barrier. This composition is used in combination with a 3 inch 18 gage galvanized metal roof deck atop the five story central tower, and with a 1 ½ inch 18 gage galvanized metal roof deck atop the second floor public access corridor spanning from the Upstate Cancer Center to the Upstate Medical University Hospital. In place of the metal deck and gypsum thermal barrier, the concrete roof deck assembly employs a poured concrete deck with a minimum of 2 inches of concrete topping. This assembly is used in one location, the lower level roof supporting auxiliary mechanical equipment.

Green roofing systems have been incorporated into the design of the Upstate Cancer Center for both aesthetic and energy saving purposes. The typical green roof assembly consists of native plants grown in approximately 12 inches of top soil. Beneath the soil surface is a composition of a drainage boards, rigid insulation, a root barrier, as well as roofing membrane. All of this is supported by a composite 3 inch 20 gage galvanized steel deck with 3 ¼ inch lightweight concrete topping, making a total thickness of 6 ¼ inches, reinforced with ASTM A185 6x6 welded wire fabric. The green roof assemblies are located atop the two story central plant as well as the single story imaging building.

## Lateral System

Full building expansion joints exist in the Upstate Cancer Center, effectively separating the Central Plant and Imaging Building from the Central Tower. Because of this, it is reasonable to assume that each portion of the cancer center behaves independently of each other under lateral loading, and therefore has its own unique lateral force resisting system. This report will only consider the analysis of the lateral systems in the Central Tower and Central Plant.

Lateral forces acting on the Central Tower are opposed by a series of ordinary steel braced frames running in the East-West and North-South directions. These braced frames generally run the full height of the building, from ground level to the roof. Braced frames are located, surrounding the elevator cores, along the exterior walls of the building, and along interior framing lines. Figure 7 shows the Central Tower and the location of braced frames, highlighted in blue, within the building at the first story. Heavy black lines denote the location of building expansion joints.

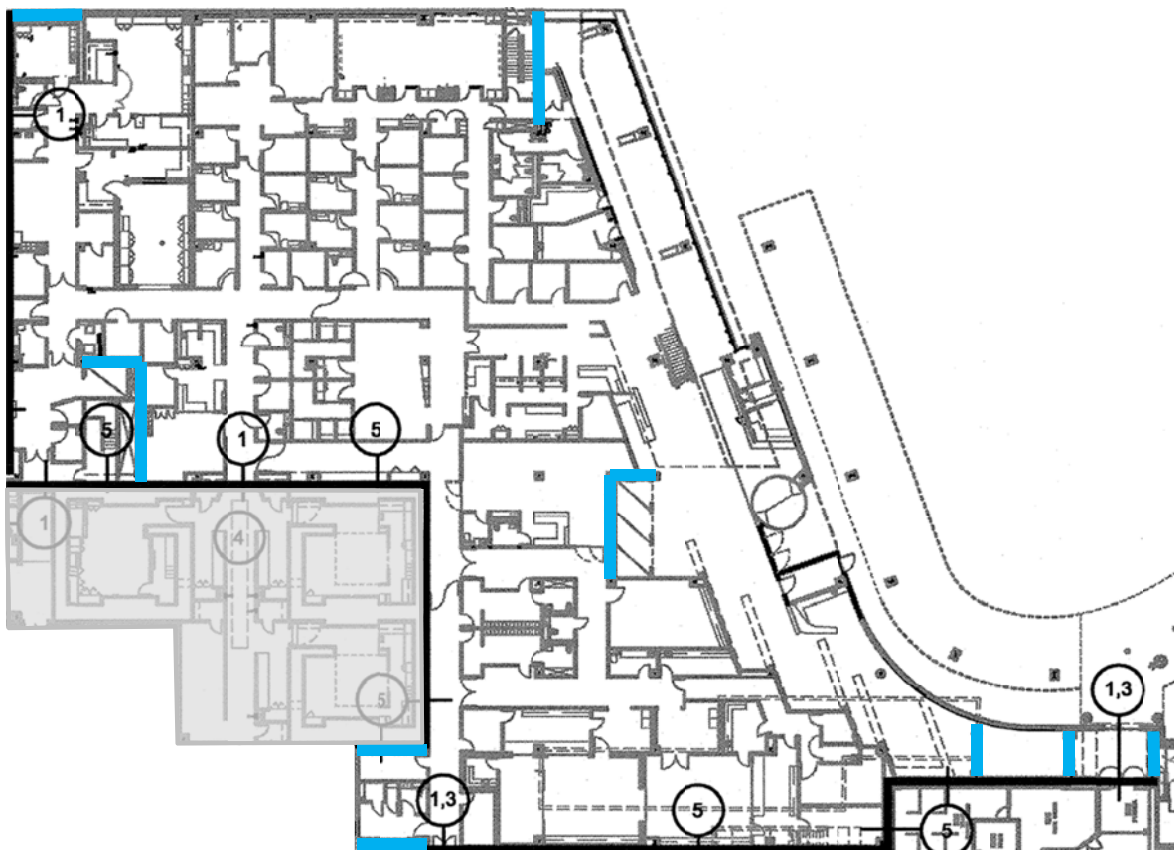

**Figure 7** Location of braced frames in the Central Tower. (Courtesy of EwingCole)

All columns used in the braced frames are W12's ranging in size from a W12x106 to a W12x210. The diagonal members used for the frames are generally W10's with W8's being used at the upper levels. Sizes of these members range from W8x31 to W10x88. The bolted connections for the frames were not detailed for seismic resistance and therefore a response modification factor of 3.0 was used for calculation purposes. Figure 8 below displays an elevation of the braced frame located long grid line 1' between lines 4' and 5'.

Braced frames are used in conjunction with moment frames in the Central Plant. Braced frames run in the East-West direction along the exterior walls of the building, while moment frames run in the North-South direction along interior framing lines. The moment frames allow for more accessible floor space to be utilized for the movement of mechanical equipment. The brace frame composition for the central plant is similar to that described previously. The typical moment frame uses a bolted moment connection with most welding prefabricated in the shop. Figure 9 shows the Central Plant with the locations of braced frames, highlighted in blue, and moment frames, highlighted in red at the first story. Heavy black lines denote the locations of expansion joints.

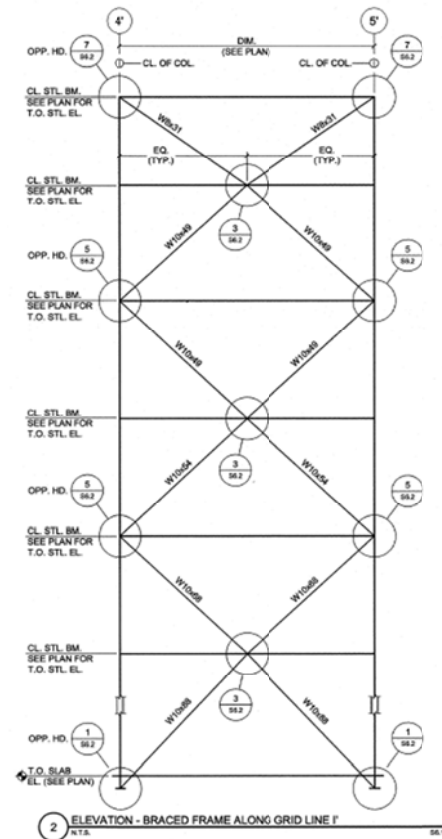

**Figure 8** Braced frame elevation along grid line 1' between lines 4' & 5' (Courtesy of EwingCole)

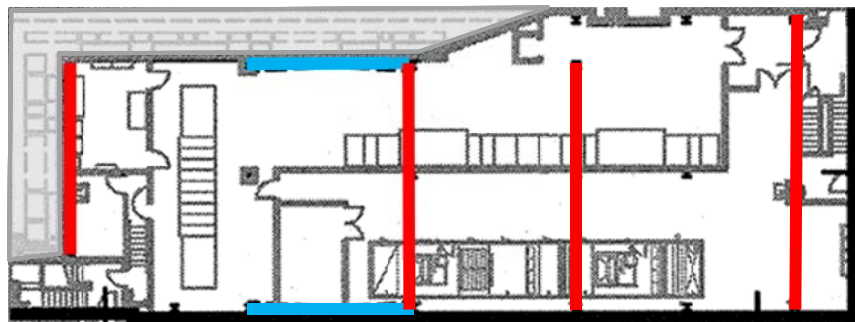

**Figure 9** Floor plans showing braced (blue) and moment (red) frames locations in the central plant). (Courtesy of EwingCole)

## Design Codes and Standards

Referencing sheet G.2.1, the following codes were applicable in the design of the Upstate Cancer Center:

- 2007 Building Code of New York State (Based on IBC 2003)
  - IBC 2003 - International Building Code, 2003 Edition
  - ASCE 7-02 – Minimum Design Loads for Buildings and Other Structures, 2002 Edition
- 1997 Life Safety Code (NFPA 101)
- Sprinkler Code – NFPA 13-02
- National Electrical Code, 2005 Edition
- 2007 Plumbing Code of New York State (Based on the 2003 IPC)
- 2007 Fire Code of New York State (Based on the 2003 IFC)
- 2007 Energy Conservation Construction Code of New York State
- 2007 Mechanical Code of New York State (Based on the 2003 IMC)
- 2007 Fuel Gas Code of New York State (Based on the 2003 IFGC)
- Accessibility – ICC/ANSI A117.1-03
- 1997 AIA Guidelines for Design & Construction of Healthcare Facilities
- Health Care – NFPA 99-1996
- Fire Alarm Code – NFPA 72-02 (Amended)
- AISC Manual of Steel Construction, 13<sup>th</sup> Edition, Load Resistance Factor Design (LRFD)

Calculations and analyses included within this report have been carried out with use of the following codes and standards:

- IBC 2009 – International Building Code, 2009 Edition
- ASCE 7-10 – Minimum Design Loads for Building and Other Structures, 2010 Edition
  - Allowable Building Drift (Wind) =  $H/400$  [ASCE Commentary Appendix C Section CC.1.2]
  - Allowable Story Drift (Seismic) =  $0.010h_{sx}$  [ASCE Table 12.12-1]
- AISC Manual of Steel Construction, 14<sup>th</sup> Edition, Load Resistance Factor Design (LRFD)
- ACI 318-08, Building Code Requirements for Structural Concrete and Commentary
- Vulcraft Steel Roof and Floor Deck 2008

\*NOTE: References made to 2007 Building Code of New York State for special case items.

## Materials

<b>Structural Steel</b>		
<b>Item</b>	<b>Grade</b>	<b>Strength, fy (ksi)</b>
Wide Flange Structural Shapes	A992 GR 50	50
Base Plates / Moment Plates / Spice Plates	ASTM 572 GR 50	50
Hollow Structural Steel	ASTM A 500 GR B	46
Angles / Channels / Other Plates	A36	36
<b>Concrete</b>		
<b>Item</b>	<b>Weight (pcf)</b>	<b>Strength, f'c (psi)</b>
Piers / Caissons	Normal Weight (145)	5000
Slab on Grade (SOG)	Normal Weight (145)	4000
Walls / Beams / Equipment Pads / Sidewalks	Normal Weight (145)	4000
Lower Mechanical Roof Slab Deck	Normal Weight (145)	3500
Typical Slab Deck	Light Weight (110)	3000
<b>Masonry</b>		
<b>Item</b>	<b>Grade</b>	<b>Strength (psi)</b>
Concrete Masonry Unit (CMU)	ASTM C 90	1900
Type S Mortar	ASTM C 270	1800
Fine Grout	--	3000
<b>Cold Formed Metal Framing</b>		
<b>Item</b>	<b>Grade</b>	<b>Strength (ksi)</b>
6" Cold Formed Metal Framing	ASTM 653	50

**Table 1** Compilation of building materials used in the design and construction of the Upstate Cancer Center.

## Problem Statement

As revealed in Technical Reports One and Three, the SUNY Upstate Cancer Center was deemed adequate in terms of strength and serviceability requirements. Currently the Upstate Cancer Center utilizes a steel superstructure, supported by cast-in-place grade beams, which in turn are supported by drilled caissons driven into bedrock. Furthermore, the superstructure can be broken down into composite metal deck on composite beams and girders with a typical bay size of 30 feet by 30 feet.

In Technical Report Two, several floor systems were researched as feasible alternatives to the existing system in place in the cancer center. Upon comparison of the systems it was determined that the two proposed reinforced concrete systems were actually less expensive than the existing steel system. Also, the two concrete systems would not require addition fireproofing, which is necessary in the steel construction. Therefore, changing the construction to reinforced concrete may lead to a lower overall cost for the building.

## Proposed Solution

Of the three alternative floor systems analyzed in Technical Report Two (Precast Hollow Core Planks on Steel Girders; Two-Way Flat Slab with Drop Panels; One-Way Pan Joist Systems) it was ultimately ruled through a pro-con comparison that the Two-Way Flat Slab with Drop Panels system was the most feasible substitute to the existing composite steel system. It was determined that this option was the least expensive of the three solutions and was the least impeding on the architectural layout and style of the building.

The proposed thesis is to redesign the SUNY Upstate Cancer Center using a Two-Way Flat Slab reinforced concrete system. Changing the construction medium to concrete will require a complete overhaul of the cancer center's gravity and lateral force resisting systems. Rectangular reinforced concrete columns will replace existing wide flange members while poured concrete shear walls will most-likely be substituted for steel braced frames. Location of shear walls must coordinate with the building layout. These significant changes will increase the mass of the structure potentially leading to a modification of the existing foundation system. If needed, the foundation of the Upstate Cancer Center will be redesigned to carry the new loads.

In addition to redesigning the gravity and lateral force resisting systems of the cancer center, it is also the author's intention to gain more knowledge in respect to the subject of progressive collapse. Once the building's gravity and lateral force resisting systems are re-evaluated, critical members will be evaluated and designed according to the Unified Facilities Criteria and the General Services Administration.

## Breadth Topics

### Breadth Topic 1 – Cost and Schedule Analysis

Altering the structural system of the Upstate Cancer Center will undoubtedly lead to significant changes regarding the construction cost and scheduling of the building. In response to this, an in-depth cost and schedule analysis will be conducted on the redesigned Upstate Cancer Center utilizing reinforced concrete. Using resources such as RS Means as well as industry information, the newly prepared cost and schedule will be compared to original documentation to examine the effects of the implemented design.

### Breadth Topic 2 – Building Envelope and Façade Study

Currently, the north-east facing façade of the building is faced with a full height glass curtain wall. A heat transfer analysis will be conducted to evaluate the effectiveness of the current wall system. Based on the outcomes of the analysis an alternative façade system will be designed with the intention of increasing efficiency focusing on sustainability. The proposed alteration will be compared against the existing curtain wall system in order to quantify the results.

## MAE Requirements

In order to meet the MAE requirements for this thesis, knowledge and skills acquired from AE 597A, Computer Modeling of Building Structures, and AE 542, Building Enclosure Science and Design, will be applied. The redesign of the Upstate Cancer Center, utilizing reinforced concrete, will be modeled using ETABS computer modeling software. In turn, forces found from the analysis will be used to design the gravity and lateral systems of the cancer center. Material covered within AE 542, will be utilized to evaluate and redesign the glass curtain wall detailed in breadth topic two.



## Tasks and Tools

1. Design Reinforced Concrete System
  - a. Confirm alternative flooring system
    - i. Further investigate two-way slab system
  - b. Redesign building's gravity system
    - i. Establish column layout
    - ii. Confirm previously calculated gravity loading / alter any necessary loads
    - iii. Design gravity load resisting system (slab / beams / drop panels / reinforcement)
    - iv. Design columns
  - c. Redesign building's lateral system
    - i. Establish lateral force resisting system
    - ii. Confirm previously calculated lateral loading / alter any necessary loads
    - iii. Design lateral force resisting system (shear walls / moment frames)
    - iv. Check building torsion and drift
  - d. Confirm and develop redesign, utilizing ETABS computer modeling software
  - e. Analyze foundation
    - i. Determine adequacy of existing foundation
    - ii. Redesign as necessary
2. Progressive Collapse Design
  - a. Research requirements for progressive collapse design
    - i. Unified Facilities Criteria (UFC)
    - ii. U.S. General Services Administration (GSA)
  - b. Select critical members / locations for design
  - c. Redesign members according to UFC and GSA guidelines
  - d. Verify design is satisfactory
3. Conduct Cost and Schedule Analysis (Breadth Topic 1)
  - a. Obtain cost and schedule information from LeChase Construction / EwingCole
  - b. Research RS Means / consult with construction manager
    - i. Cost information
    - ii. Scheduling information
  - c. Prepare cost and schedule analysis
    - i. Material Cost
    - ii. Labor Cost
    - iii. Scheduling
  - d. Compare new and existing cost and schedule
4. Conduct Building Envelope and Façade Study (Breadth Topic 2)
  - a. Gather information regarding existing façade from EwingCole
  - b. Research alternative solutions considering:
    - i. Cost

- ii. Energy savings
  - c. Redesign façade, if necessary
  - d. Compare original and new façade design (if needed)
- 5. Final Report and Presentation
  - a. Compile and format final report
  - b. Finalize Report
  - c. Outline presentation
  - d. Create presentation slides
  - e. Practice presentation

## Timeline (Spring Semester)

Michael Kostick		Structural Option		Dr. Richard Behr		December 9, 2011		SUNY Upstate Cancer Center - Syracuse, New York							
Proposed Thesis Schedule															
January 2012 - April 2012															
9-Jan-12	16-Jan-12	23-Jan-12	30-Jan-12	6-Feb-12	13-Feb-12	20-Feb-12	27-Feb-12	5-Mar-12	12-Mar-12	19-Mar-12	26-Mar-12	2-Apr-12	9-Apr-12	16-Apr-12	23-Apr-12
		<b>1/27/2012 Milestone 1</b>			<b>2/13/2012 Milestone 2</b>		<b>3/2/2012 Milestone 3</b>	Spring Break			<b>3/26/2012 Milestone 4</b>				
Confirm Alternative Flooring System															
	Design Reinforced Concrete System														
	Design & Verify New Gravity System														
		Design and Verify New Lateral System													
					Evaluate / Redesign Existing Foundation										
					Research Progressive Collapse Requirements										
					Perform Progressive Collapse Redesign										
	Obtain Cost & Schedule from LeChase Construction														
	Obtain Curtain Wall / Façade information from EwngCole														
								Conduct Cost & Schedule Analysis / Compare to Existing							
							Research Alternative Façade Design								
							Perform Façade Analysis / Compare to Existing								
							Write & Format Final Report								
							Create Final Presentation								
												Final Reports Due Wednesday April 4, 2012			
													Faculty Jury Presentations		
															Senior Banquet / Last Day of Class - Friday April 27, 2012
															ABET Evaluations and Update CPEP Website

Milestones	
1	New Gravity System Designed & Verified
2	New Lateral System Designed & Verified
3	Progressive Collapse Design Complete
4	Cost & Schedule / Building Envelope & Façade Study Complete

Structural Depth	
Breadth Topic 1: Cost and Schedule Analysis	
Breadth Topic 2: Building Envelope and Façade Study	
Report and Presentation	
Course / Semester Wrap-Up	

## Conclusion

Proposed thesis work for the spring semester will focus on redesigning the structural system of the SUNY Upstate Cancer Center, utilizing reinforced concrete in place of the existing steel superstructure. Furthermore, the gravity and lateral load resisting systems will be reconfigured based on the new construction medium. Of the three alternative flooring systems explored in Technical Report 2, it was determined that the two-way slab system would be the most viable solution to replace the existing composite steel system. Additional evaluation of this floor system will be conducted to ensure its feasibility for the cancer center's redesign. Once a preliminary design has been completed, the Upstate Cancer Center will be designed to comply with progressive collapse requirements established by the Unified Facilities Criteria (UFC) and the General Services Administration (GSA). Finally the existing foundation will be studied to determine if change in the building's superstructure will require any changes to the substructure. Alterations will be made as needed.

It is believed that redesigning the Upstate Cancer Center using reinforced concrete will alter its existing cost and schedule. Therefore a construction management breadth examining the changes in cost and schedule between the two systems will be conducted. Also a second breadth study, analyzing heat transfer and energy efficiency of the north-east facing glass curtain wall will be performed. This analysis will lead to the potential redesign of the glazed façade, aimed to improve its effectiveness.